

GB1

20/25 GPM
grease interceptor

Specification and Submittal

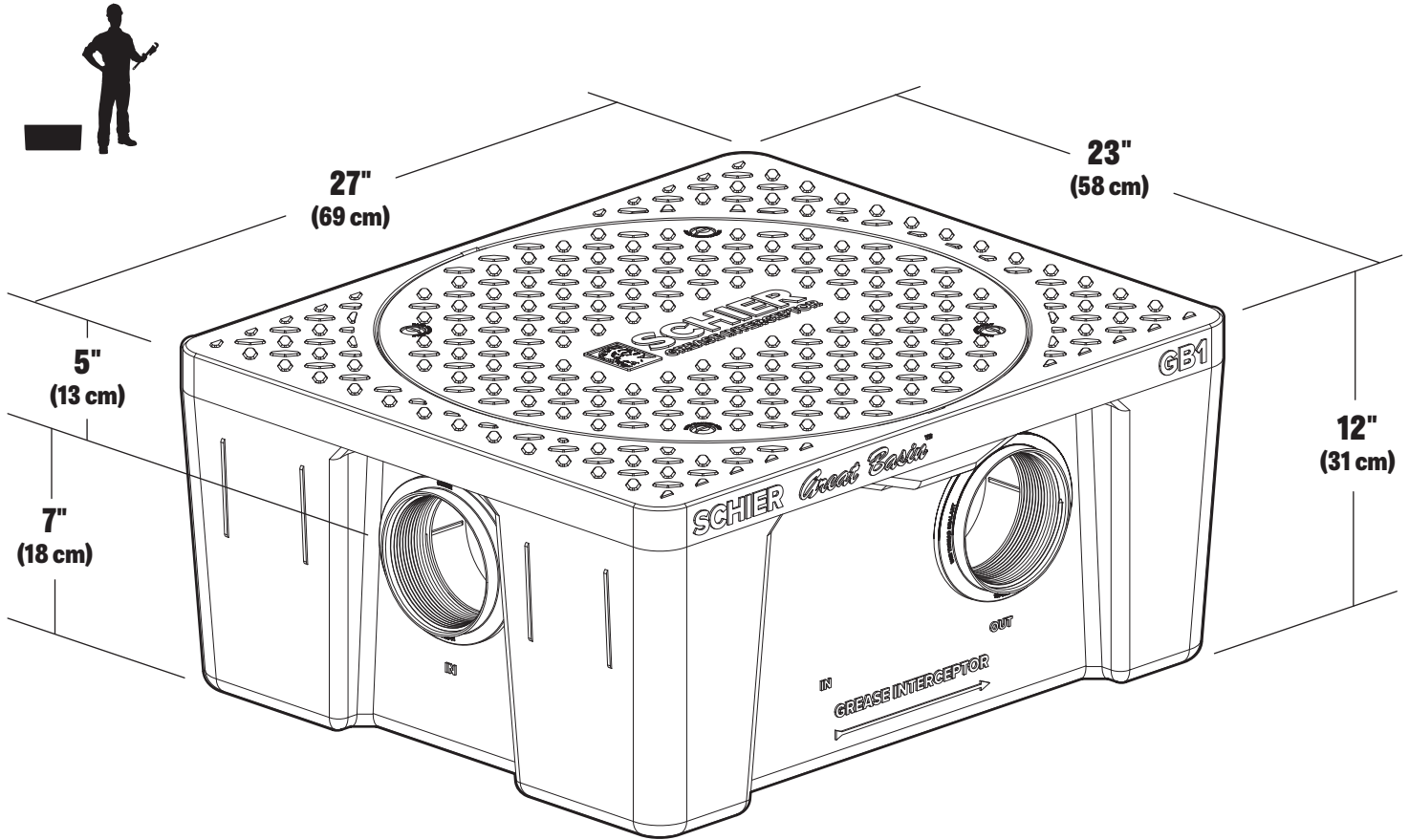

SUBMITTAL

Standard

Location: indoor

Installation: above/below grade

Flow Rates / Grease Capacities:
20 GPM (1.3 L/s) / 70 lbs. (31.8 kg)
25 GPM (1.6 L/s) / 64.9 lbs. (29.4 kg)

Solids Capacity: 1.3 gal. (4.9 L)

Liquid Capacity: 10 gal. (37.9 L)

Weight: 39 lbs. (17.7 kg)

Connections: 2" (50 mm)
and 3" (75 mm) plain end

Cover: bolted gas/water tight polypropylene
with 1,000 lb. load rating when unit is buried
with FCR1 riser

Options

- FCR1 (x1):** > 2-1/8" - 12" field cut riser
- FCR1 (x2):** > 12" - 24" field cut risers
- CC1:** membrane clamping collar kit
(requires FCR1 riser)
- PP1:** pumpout port kit
- F32:** 3" x 2" (75 mm x 50 mm) FPT fittings (x2)

Approval

Signature:	Date:	Company:
Specifying Engineer:		Engineering Firm:



SCHIER
LIFETIME GUARANTEED
GREASE INTERCEPTORS

MODEL NUMBER:
GB1

DESCRIPTION: 20/25 GPM Polyethylene Grease Interceptor

PART #: 4060-001-03

DWG BY: B. Karrer

DATE: 9/1/2018

REV:

ECO:



SPECIAL PRECAUTIONS

For All Schier Grease Interceptor Installations - Failure to follow this guidance voids your warranty

Installation Instructions

Installation instructions and additional components are included with the interceptor. Read all instructions prior to installation. This interceptor is intended to be installed by a licensed plumber in conformance with all local codes.

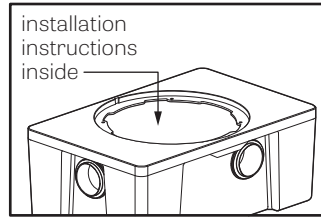

When Installing Interceptor Inside

If your dishwashing sink(s) discharges into a floor drain/sink (drain), you must regulate the flow into the drain to avoid an overflow of water onto the kitchen floor. This can be done by installing a valve or flow restriction cap on the sink piping that discharges into the drain. See drawing above for guidance. For detailed guidance on indirect connections, go to:

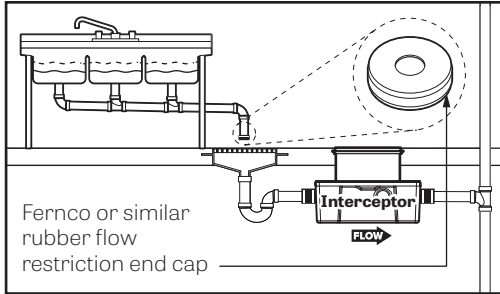

http://webtools.schierproducts.com/Technical_Data/Indirect_Connections.pdf

Flush-to-Grade Burials

Flush-to-Grade buried installations (without a riser) are not recommended for heavy foot traffic areas without the use of an internal support system (sold additionally).

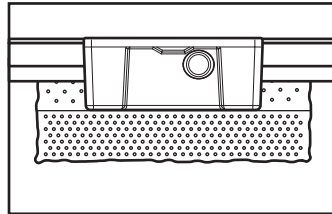

High Temperature Kitchen Water

If water is entering the interceptor at excessive temperature (over 140° F), a drain water tempering valve (DTV) and approved backflow prevention assembly must be installed. Most state and local plumbing codes prohibit water above 140° F being discharged into the sanitary sewer. Water above 140° F will weaken or deform PVC Schedule 40 pipe, poly drainage fixtures like interceptors and erode the coating of cast iron (leading to eventual failure).

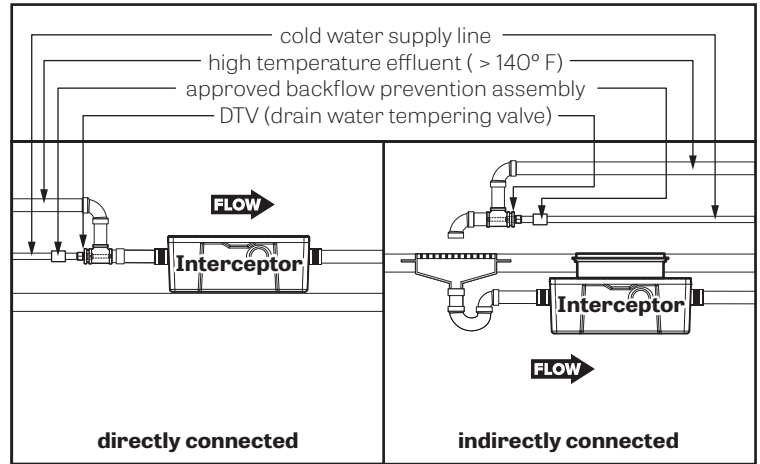

Fully Support Base of Unit

Install unit on solid, level surface in contact with the entire footprint of unit base; for suspended installations design trapeze to support the wet weight of the unit. Do not partially support unit or suspend unit using metal U-channel to create a trapeze

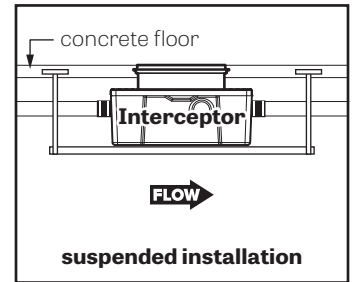

Support Inlet and Outlet Piping

For above grade installations ensure heavy inlet and outlet piping (such as cast iron or long runs) is properly supported or suspended during the entire installation process to prevent connection failure or damage to bulkhead fittings.

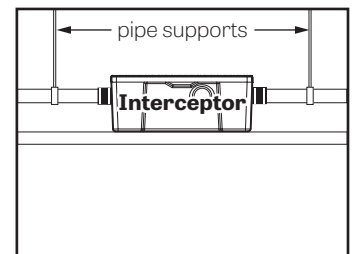

SCHIER
LIFETIME GUARANTEED
GREASE INTERCEPTORS

MODEL NUMBER:
GB1

DESCRIPTION: 20/25 GPM Polyethylene Grease Interceptor

PART #: 4060-001-03

DWG BY: B. Karrer

DATE: 9/11/2018

REV:

ECO:

SPECIFICATION

Notes

1. 4" FPT inlet/outlet with 2" and 3" plain end fittings.
2. Unit weight - 39 lbs. (wet weight 123 lbs.)
3. Capacities - Liquid: 10 gal.
 @20 GPM- Grease: 70 lbs. (9.6 gal.)
 @25 GPM- Grease: 64.9 lbs. (8.9 gal.)
 Solids: 1.3 gal.
4. Built-in flow control.
5. For gravity drainage applications only.
6. Do not use for pressure applications.
7. Cover placement allows full access to tank for proper maintenance.
8. Vent not required unless per local code.
9. Engineered inlet and outlet diffusers are removable to inspect/clean piping.
10. Integral air relief / anti-siphon.

Engineer Specification Guide

Schier Great Basin™ grease interceptor model # GB1 shall be lifetime guaranteed and made in USA of seamless, rotationally-molded polyethylene. Interceptor shall be furnished for above or below grade installation. Interceptor shall be certified to ASME A112.14.3 (type C) and CSA B481.1, with field cut riser system, built-in flow control, built-in test caps and three outlet options. Interceptor flow rate shall be 20 or 25 GPM. Interceptor grease capacity shall be 70 lbs. @ 20 GPM or 64.9 lbs. @ 25 GPM. Cover shall provide water/gas-tight seal and have minimum 450 lbs. load capacity.

Certified Performance

Great Basin™ hydromechanical grease interceptors are third party performance-tested and listed by IAPMO to ASME #A112.14.3 and CSA B481.1 grease interceptor standards and greatly exceed requirements for grease separation and storage. They are compliant to the Uniform Plumbing Code, the National Standard Plumbing Code, the National Plumbing Code of Canada, and the International Plumbing Code.

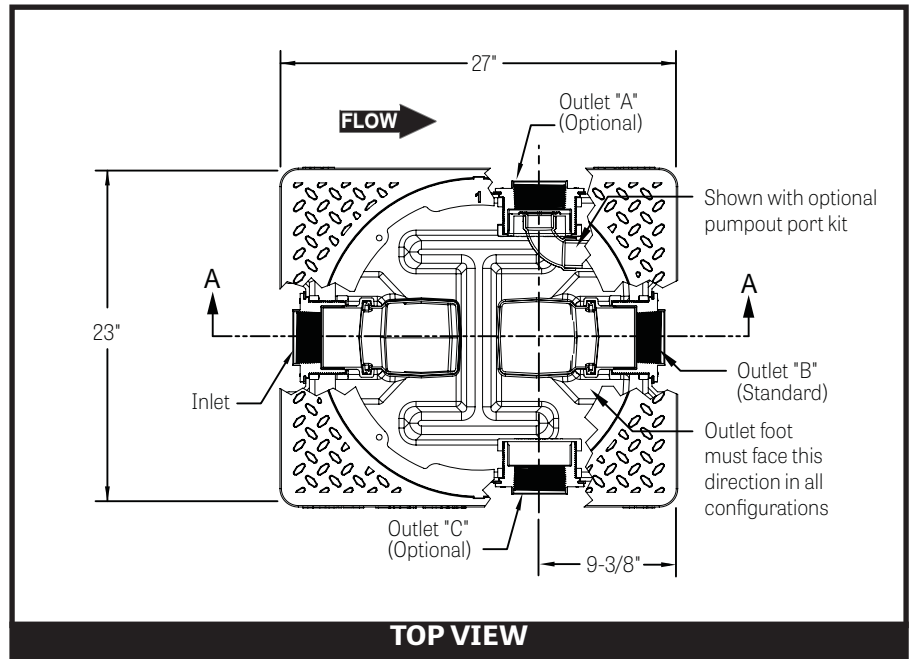

TOP VIEW

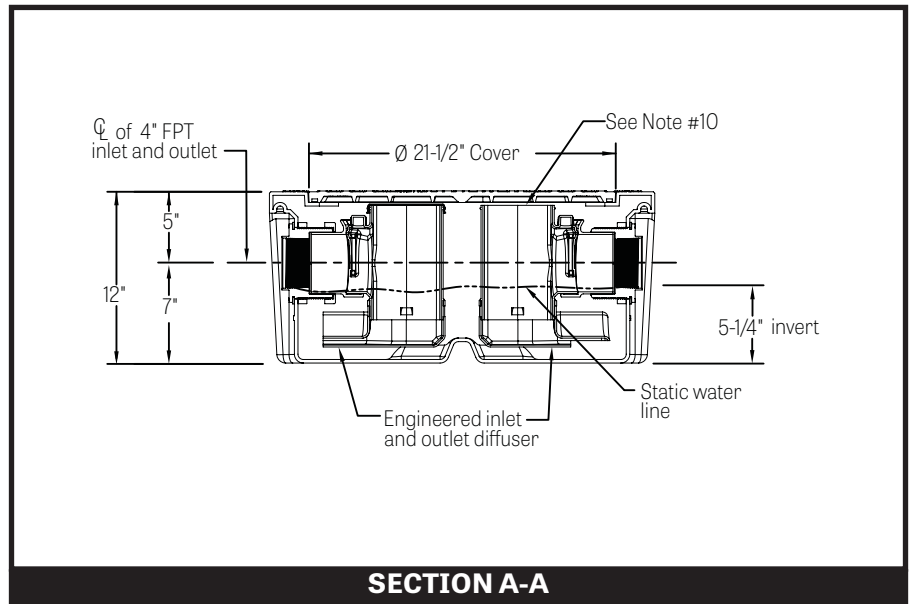

SECTION A-A

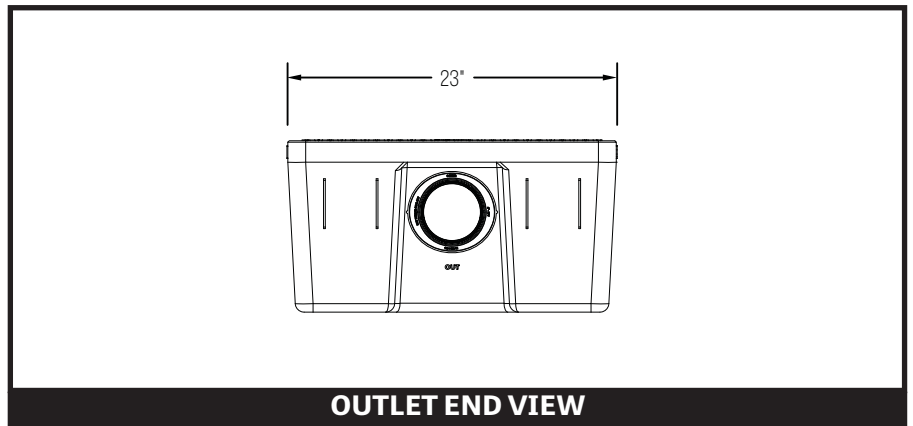

OUTLET END VIEW



SCHIER
LIFETIME GUARANTEED
GREASE INTERCEPTORS

MODEL NUMBER:
GB1

DESCRIPTION: 20/25 GPM Polyethylene Grease Interceptor

PART #: 4060-001-03

DWG BY: B. Karrer

DATE: 9/1/2018

REV:

ECO: